

KNOLL
.It works



Kreiselpumpen Centrifugal Pumps

Die KNOLL-Kreiselpumpe steht für viele Vorteile.
The KNOLL centrifugal pump type T has many advantages.

2. Hohe Belastbarkeit aufgrund solider Wellen-Nabenverbindung
 High rigidity with its solid shaft-hub connection

1. Sehr hoher Wirkungsgrad durch strömungstechnisch günstig geformtes Laufrad
 Very high efficiency because of flow favorable formed impeller

3. Sehr hohe Lebenszeit mit robustem Gusseisen-Gehäuse
 Very long life-time with the sturdy cast-iron housing

4. Kostengünstige Fertigung durch modularen Aufbau
 Less production costs because of modular design

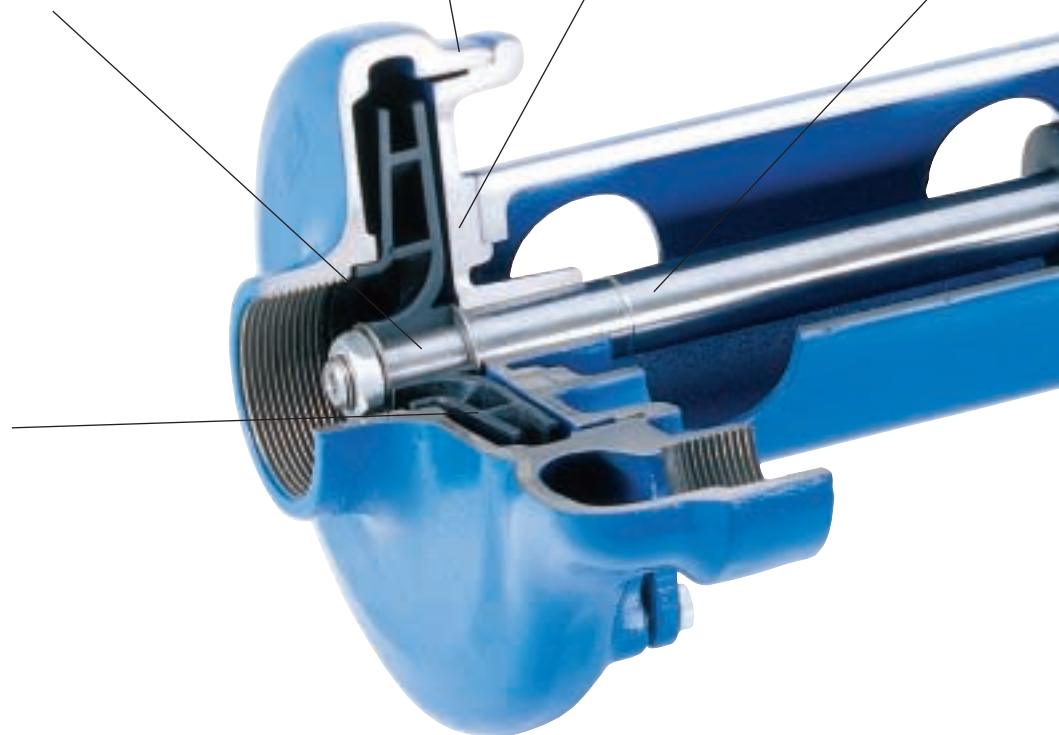

Anwendungsbereiche

KNOLL-Kreiselpumpen sind Tauchpumpen, die auf drucklose Behälter oder Schächte montiert werden und in das Medium eintauchen.

- Vorwiegend geeignet zum Fördern von Kühlschmiermitteln (Wasser, Emulsion, Öl) und Waschwasser mit Korngrößen bis 30 mm und $v < 30 \text{ mm}^2/\text{s}$
- Eingesetzt an Werkzeugmaschinen zur Kühlschmiermittelversorgung und -reinigung sowie an Reinigungs-/Entfettungsanlagen
- Maximale Leistungsdaten
 $Q = 96 \text{ m}^3/\text{h}$ (1600 l/min)
 $p = 6 \text{ bar}$
 $T = 60 \text{ }^\circ\text{C}$

Konstruktion

Bauart

Vertikale Kreiselpumpe mit folgenden Merkmalen:

- Normalsaugend, einstufig, dichtungslos
- Verlängerte, fliegend gelagerte Motorwelle mit Spritzring
- Druckstufen radial, nach oben abgewinkelt, Saugstutzen axial
- Laufrad geschlossen (Baureihe TG) oder offen (Baureihe TF)
- Mit Pumpenblech und Druckrohr

Antrieb

Drehstrom-Kurzschlussläufermotor

- Bauart V 18, Schutzart IP 54, Isolierstoffklasse B
- 220-240 V (Δ) / 380-420 V (Y), 50 Hz, 2900 min^{-1}
- 220-265 V (Δ) / 380-460 V (Y), 60 Hz, 3500 min^{-1}

Werkstoffe

- Motorwelle E 335 (St 60-2)
- Pumpenblech S 235 JR (St 37-2)
- Motorlaterne GJL-200 (GG 20)
- Spiralgehäuse GJL-200 (GG 20)
- Gehäusedeckel GJL-200 (GG 20)
- Laufrad POM oder GJL-250 (GG 25)

5.

Trockenlaufsicherheit durch fliegend gelagerte Welle

Safe of dry running because of taper bore mounting

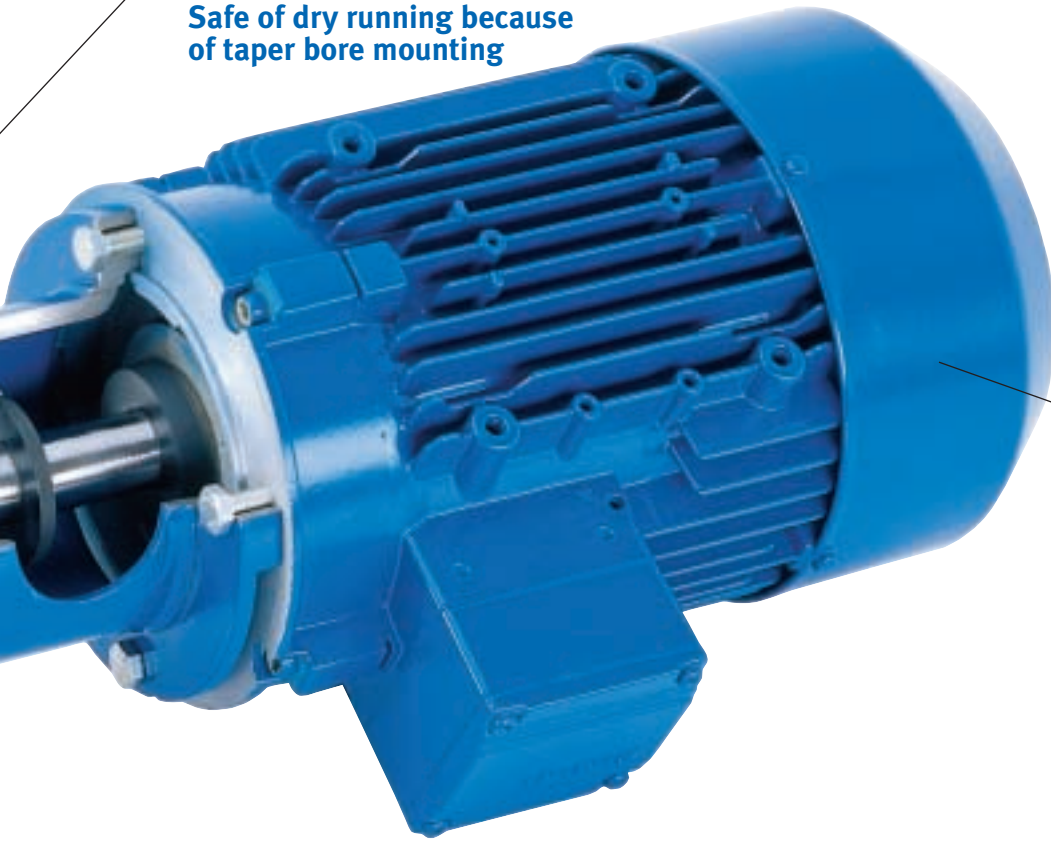

6.

Lange Lebensdauer dank Normmotor mit verlängerter Welle

Long life-time because of a standard motor with an extended shaft

Range of application

KNOLL centrifugal pumps are suitable for immersion into the medium. They can be mounted on pressureless tanks or chutes.

- Mainly suitable for conveying cooling lubricant (water, emulsion, oil) and washings containing grain sizes up to 30 mm and $v < 30 \text{ mm}^2/\text{s}$
- Applied at machine tools for supply with cleaning of cooling lubricant as well as application on cleaning equipment and degreasing units
- Maximum performance data
 $Q = 93 \text{ m}^3/\text{h}$ (1600 l/min)
 $p = 6 \text{ bar}$
 $T = 60 \text{ }^\circ\text{C}$

Construction

Type

Vertical centrifugal pump showing the following characteristics:

- Normal suction, single stage, without sealing
- Extended taper bore mounted motor axle without sealing
- Pressure connection is radial and bent upwards, suction connection is axial
- Impeller closed (type TG) or open (type TF)
- With pump plate and pressure pipe

Drive

Three-phase squirrel-cage motor

- Type V 18, protection IP 54, insulated material class B
- 220-240 V (Δ) / 380-420 V (Y), 50 Hz, 2900 min^{-1}
- 220-265 V (Δ) / 380-460 V (Y), 60 Hz, 3500 min^{-1}

Material

- | | |
|-----------------|------------------------|
| • Motor shaft | E 335 (St 60-2) |
| • Pump plate | S 235 JR (St 37-2) |
| • Motor lantern | GJL-200 (GG 20) |
| • Spiral casing | GJL-200 (GG 20) |
| • Housing cover | GJL-200 (GG 20) |
| • Impeller | POM or GJL-250 (GG 25) |

TG 25

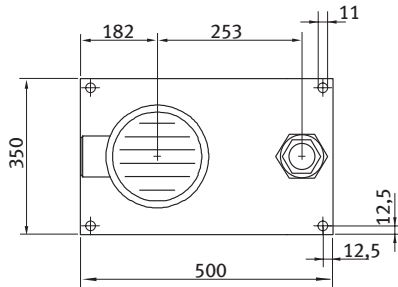
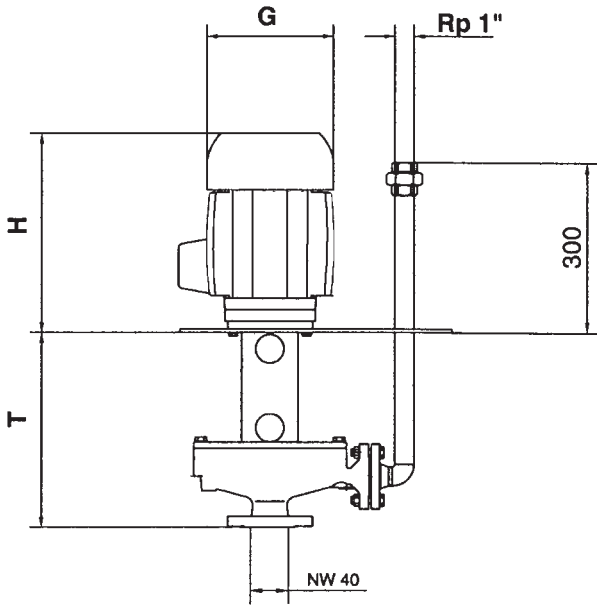

Typ/Type	T ¹⁾	H	G	Gewicht Weight (kg)	Leistung Power (kW)
TG 25-../22 345	345	320	180	47	2,2
TG 25-../30 345	345	350	200	49	3,0
TG 25-../22 590	590	320	180	51	2,2
TG 25-../30 590	590	350	200	53	3,0

Beispiel: Laufrad- $\varnothing = 158 \rightarrow$ TG 25-58/22 345

Example: Impeller- $\varnothing = 158 \rightarrow$ TG 25-58/22 345

Max. Korngröße: 1 mm
 Laufrad-Werkstoff: GJL-250 (GG 25)
 Kennlinien für $\nu = 1 \text{ mm}^2/\text{s}$

1) Maße in mm

Max. grain size: 1 mm
 Impeller material: GJL-250 (GG 25)
 Characteristic lines for $\nu = 1 \text{ mm}^2/\text{s}$
 1) Dimensions in mm

Tauchpumpe — TG 25-58/22 345
 Laufradform —
 Baugröße —
 Laufrad-Index —
 Motorleistung x 10 —
 Eintauchtiefe in mm —

Nenn Drehzahl / Nominal rotation speed 2900 min⁻¹ @ 50Hz

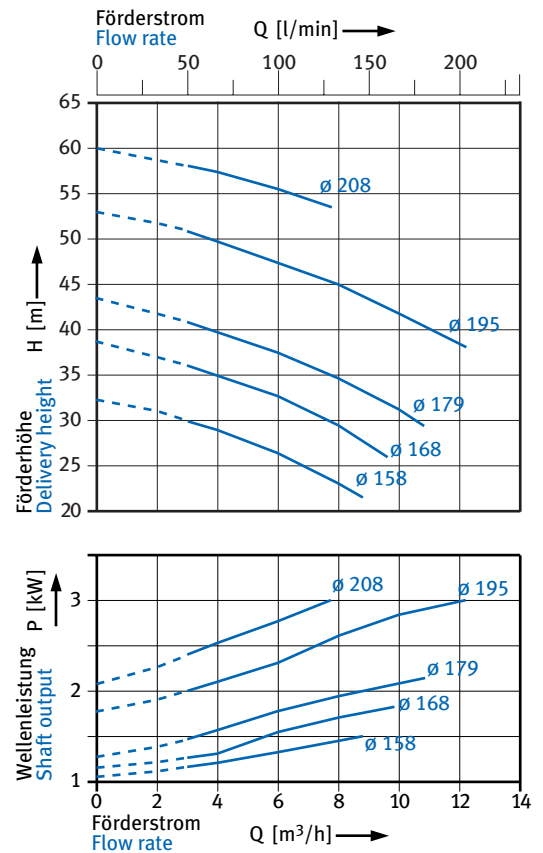

Nenn Drehzahl / Nominal rotation speed 3500 min⁻¹ @ 60Hz

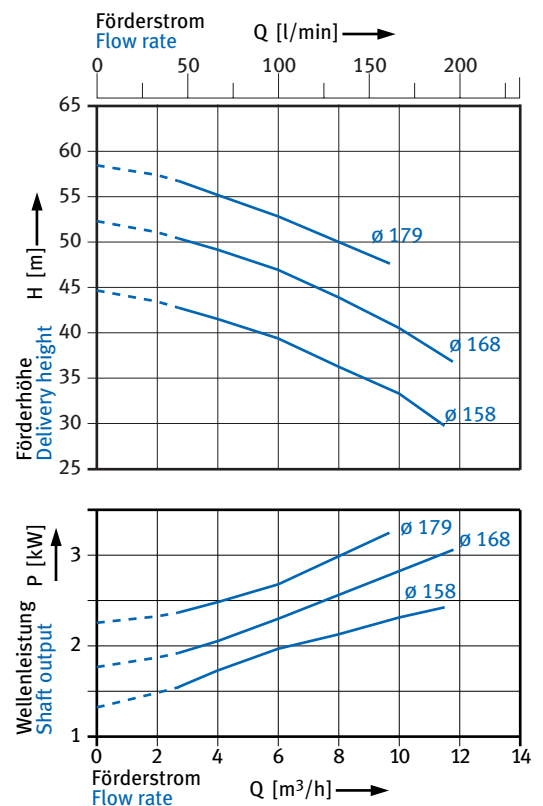

Submerged pump — TG 25-58/22 345
 Form of impeller —
 Pump size —
 Impeller-index —
 Motor power x 10 —
 Depth of immersion in mm —

TG 30

Nenn Drehzahl / Nominal rotation speed 2900 min⁻¹@ 50Hz

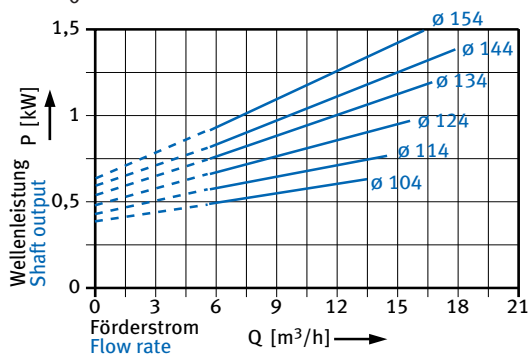
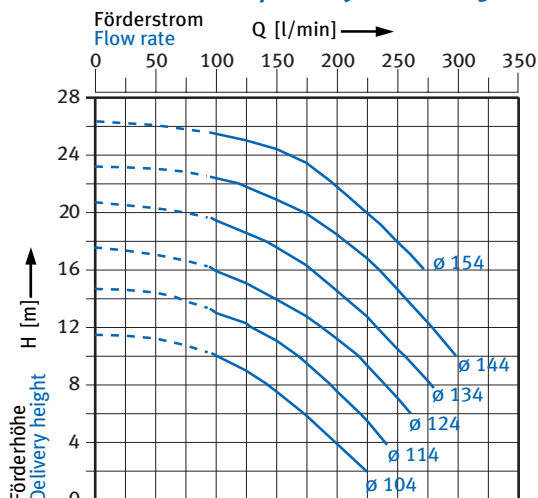

Nenn Drehzahl / Nominal rotation speed 3500 min⁻¹@ 60Hz

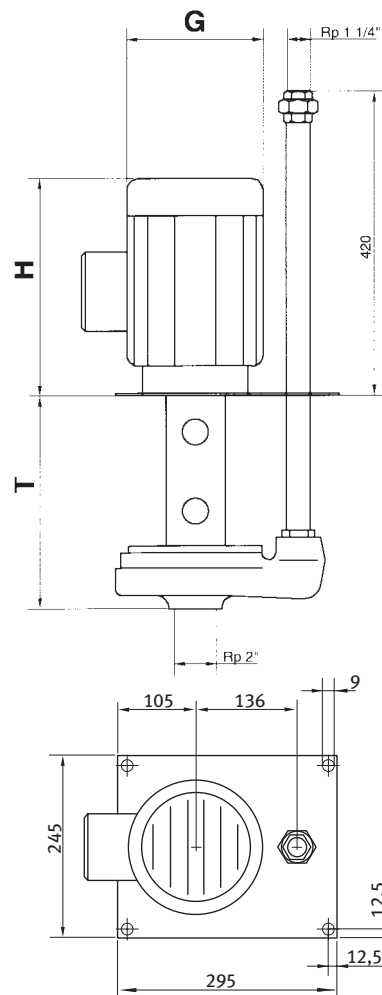
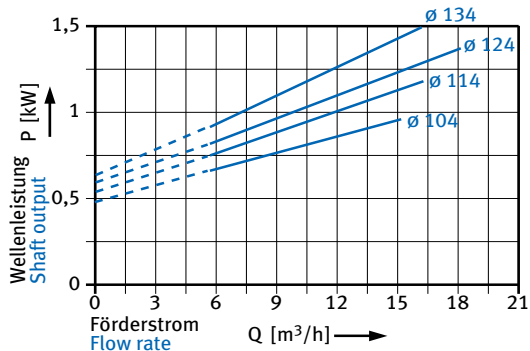
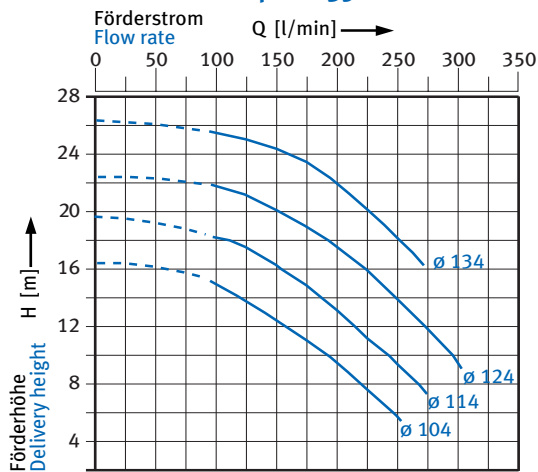

Typ/Type	T ¹⁾	H	G	Gewicht Weight (kg)	Leistung Power (kW)
TG 30-../07 285	285	270	160	23	0,75
TG 30-../11 285	285	270	160	24	1,1
TG 30-../15 285	285	290	180	27	1,5
TG 30-../07 533	533	270	160	30	0,75
TG 30-../11 533	533	270	160	31	1,1
TG 30-../15 533	533	290	180	34	1,5

Beispiel: Laufrad-Ø = 154 → TG 30-54/15285

Example: Impeller-Ø = 154 → TG 30-54/15285

Tauchpumpe ——— TG 30-54/15 285
 Laufradform ———
 Baugröße ———
 Laufrad-Index ———
 Motorleistung x 10 ———
 Eintauchtiefe in mm ———

Submerged pump ——— TG 30-54/15 285
 Form of impeller ———
 Pump size ———
 Impeller-index ———
 Motor power x 10 ———
 Depth of immersion in mm ———

Max. Korngröße: 1 mm
 Laufrad-Werkstoff: POM
 Kennlinien für $\nu = 1 \text{ mm}^2/\text{s}$
 1) Maße in mm

Max. grain size: 1 mm
 Impeller material: POM
 Characteristic lines for $\nu = 1 \text{ mm}^2/\text{s}$
 1) Dimensions in mm

TG 32

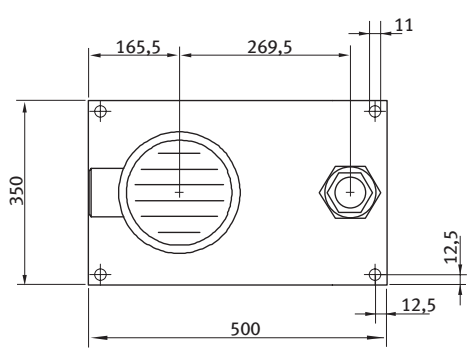
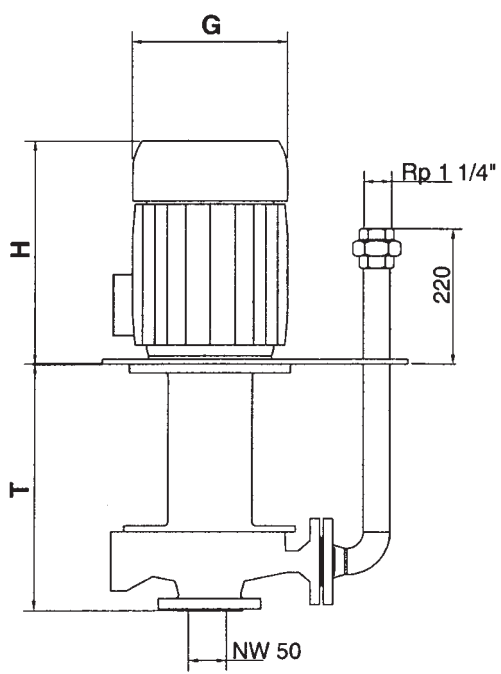

Typ/Type	T ¹⁾	H	G	Gewicht Weight (kg)	Leistung Power (kW)
TG 32-../55 400	400	370	252	100	5,5
TG 32-../75 400	400	370	252	106	7,5

Beispiel: Laufrad-Ø = 178 → TG 32-78/75 400
 Example: Impeller-Ø = 178 → TG 32-78/75 400

Max. Korngröße: 2 mm
 Laufrad-Werkstoff: GJL-250 (GG 25)
 Kennlinien für $\nu = 1 \text{ mm}^2/\text{s}$

1) Maße in mm

Max. grain size: 2 mm
 Impeller material: GJL-250 (GG 25)
 Characteristic lines for $\nu = 1 \text{ mm}^2/\text{s}$
 1) Dimensions in mm

Tauchpumpe — TG 32-78/75 400
 Laufradform —
 Baugröße —
 Laufrad-Index —
 Motorleistung x 10 —
 Eintauchtiefe in mm —

Submerged pump — TG 32-78/75 400
 Form of impeller —
 Pump size —
 Impeller-index —
 Motor power x 10 —
 Depth of immersion in mm —

Nenn Drehzahl / Nominal rotation speed 2900 min⁻¹ @ 50Hz

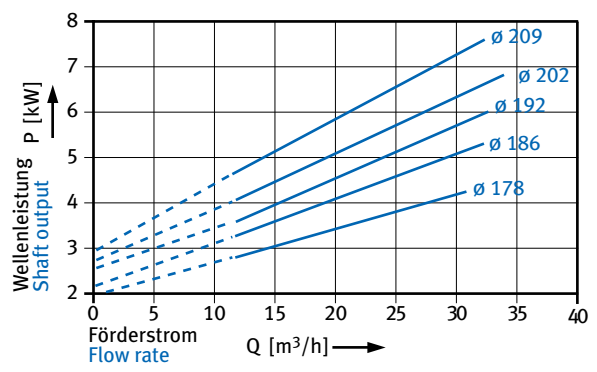
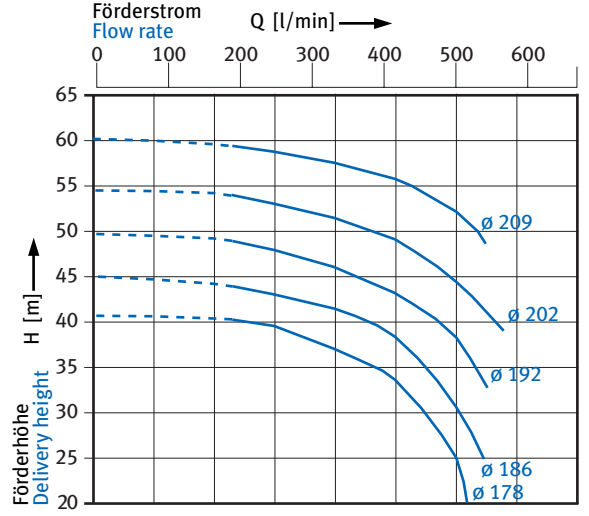

Nenn Drehzahl / Nominal rotation speed 3500 min⁻¹ @ 60Hz

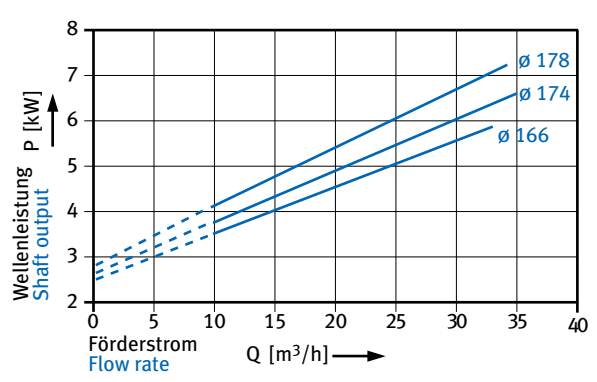
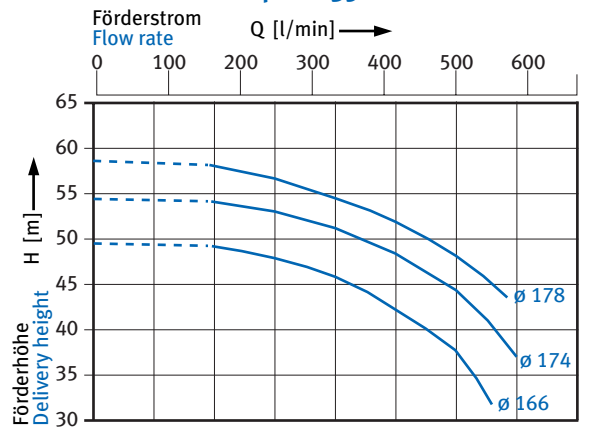

TG 40

Nenn Drehzahl / Nominal rotation speed 2900 min⁻¹ @ 50Hz

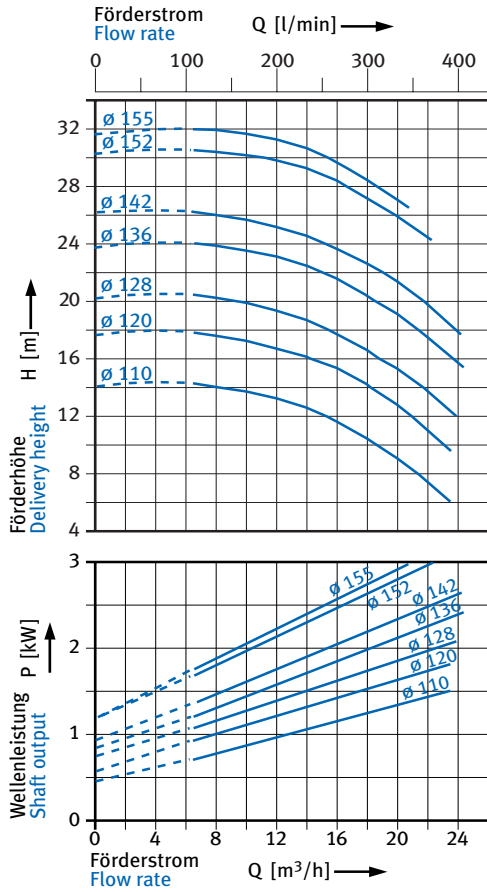

Nenn Drehzahl / Nominal rotation speed 3500 min⁻¹ @ 60Hz

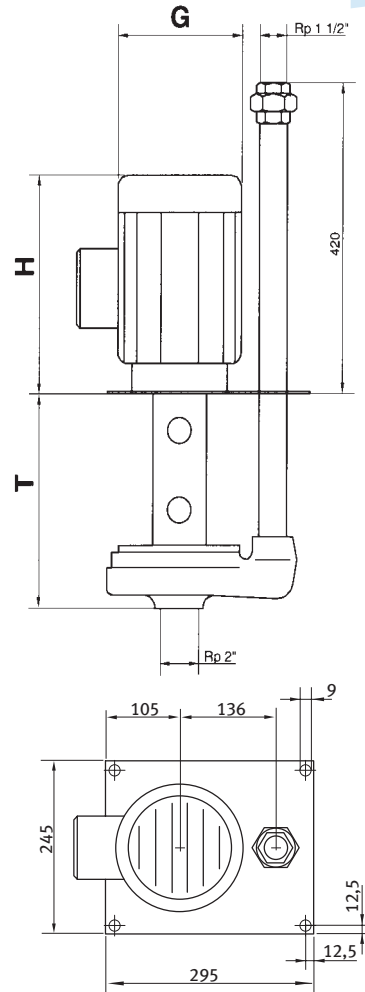
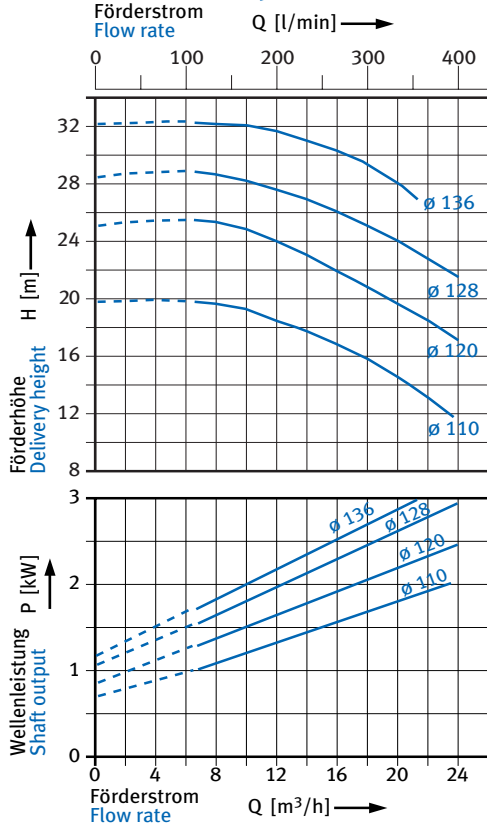

Typ/Type	T ¹⁾	H	G	Gewicht (kg) Weight	Leistung (kW) Power
TG 40-../11 285	285	270	160	25	1,1
TG 40-../15 285	285	290	180	28	1,5
TG 40-../22 285	285	320	180	31	2,2
TG 40-../30 285	285	350	200	35	3,0
TG 40-../11 533	533	270	160	32	1,1
TG 40-../15 533	533	290	180	35	1,5
TG 40-../22 533	533	320	180	38	2,2
TG 40-../30 533	533	350	200	42	3,0

Beispiel: Laufrad-Ø = 155 → TG 40-55/30285

Example: Impeller-Ø = 155 → TG 40-55/30285

Tauchpumpe — TG 40-55/30 285
 Laufradform —
 Baugröße —
 Laufrad-Index —
 Motorleistung x 10 —
 Eintauchtiefe in mm —

Submerged pump — TG 40-55/30 285
 Form of impeller —
 Pump size —
 Impeller-index —
 Motor power x 10 —
 Depth of immersion in mm —

Max. Korngröße: 3 mm
 Laufrad-Werkstoff: POM
 Kennlinien für $\nu = 1 \text{ mm}^2/\text{s}$
 1) Maße in mm

Max. grain size: 3 mm
 Impeller material: POM
 Characteristic lines for $\nu = 1 \text{ mm}^2/\text{s}$
 1) Dimensions in mm

TF 40

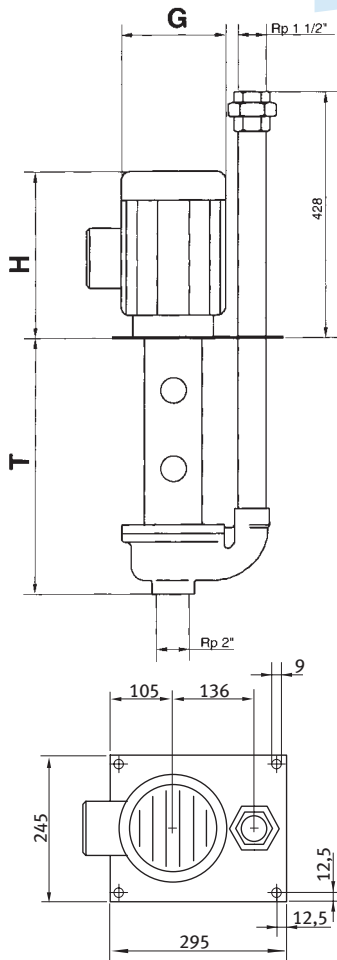

Typ/Type	T ¹⁾	H	G	Gewicht Weight (kg)	Leistung Power (kW)
TF 40-../07 330	330	270	160	26	0,75
TF 40-../11 330	330	270	160	27	1,1
TF 40-../15 330	330	290	180	30	1,5
TF 40-../22 330	330	320	180	33	2,2
TF 40-../30 330	330	350	200	37	3,0
TF 40-../07 578	578	270	160	33	0,75
TF 40-../11 578	578	270	160	34	1,1
TF 40-../15 578	578	290	180	37	1,5
TF 40-../22 578	578	320	180	40	2,2
TF 40-../30 578	578	350	200	44	3,0

Beispiel: Laufrad-Ø = 115 → TF 40-15/30 330

Example: Impeller-Ø = 115 → TF 40-15/30 330

Max. Korngröße: 15 mm
 Laufrad-Werkstoff: POM
 Kennlinien für $\nu = 1 \text{ mm}^2/\text{s}$
 1) Maße in mm

Max. grain size: 15 mm
 Impeller material: POM
 Characteristic lines for $\nu = 1 \text{ mm}^2/\text{s}$
 1) Dimensions in mm

Tauchpumpe — TF 40-15/30 330
 Laufradform —
 Baugröße —
 Laufrad-Index —
 Motorleistung x 10 —
 Eintauchtiefe in mm —

Nenn Drehzahl / Nominal rotation speed 2900 min⁻¹ @ 50Hz

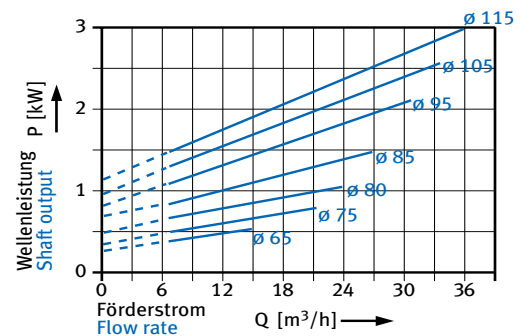
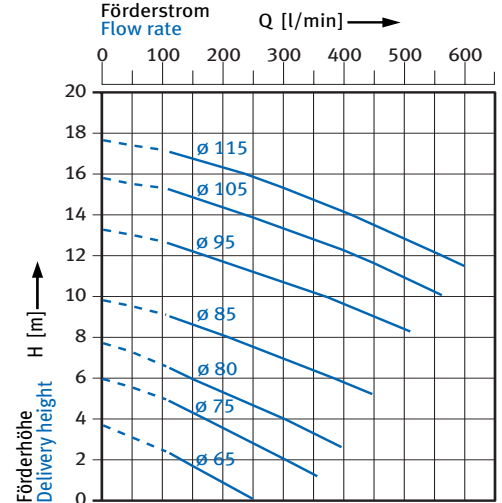

Nenn Drehzahl / Nominal rotation speed 3500 min⁻¹ @ 60Hz

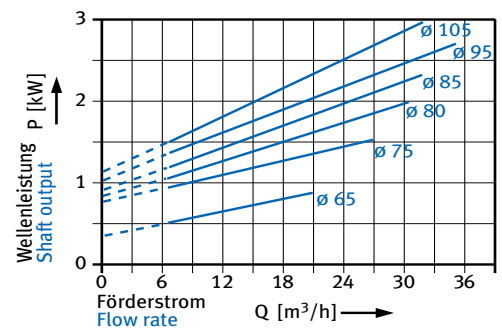
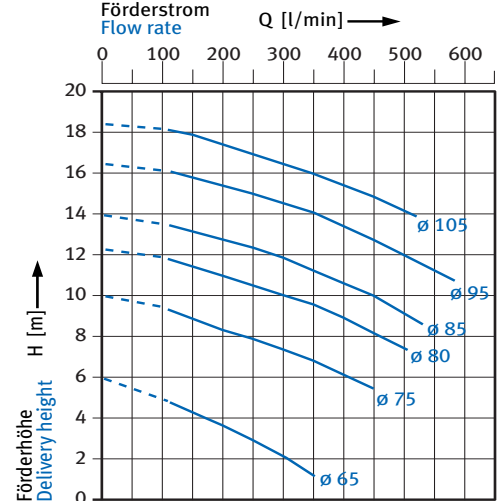

Submerged pump — TF 40-15/30 330
 Form of impeller —
 Pump size —
 Impeller-index —
 Motor power x 10 —
 Depth of immersion in mm —

TS 40

Nennzahl /
Nominal rotation speed 2900 min⁻¹ @ 50Hz

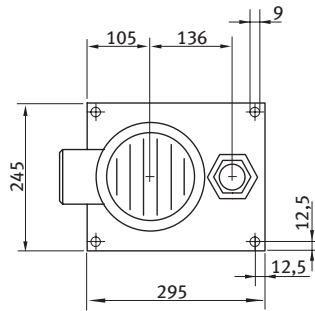
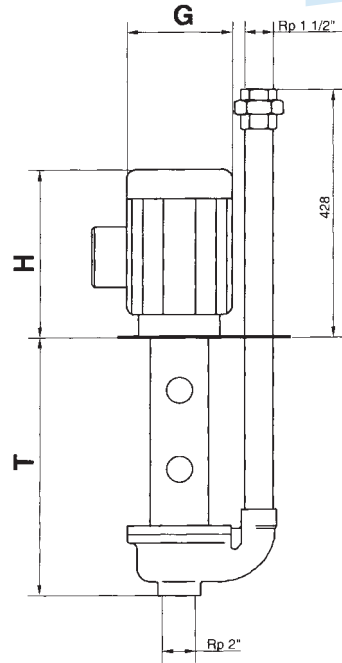
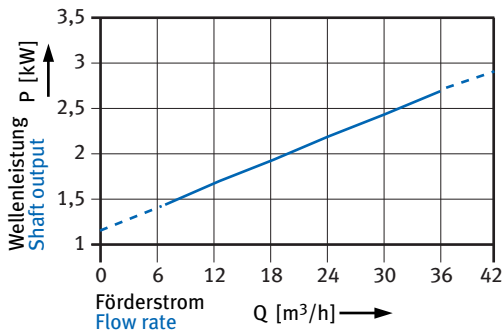
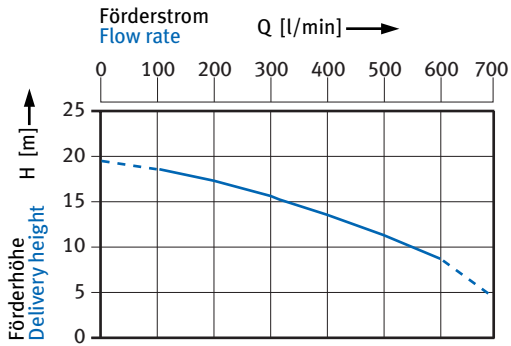

Nennzahl /
Nominal rotation speed 3500 min⁻¹ @ 60Hz

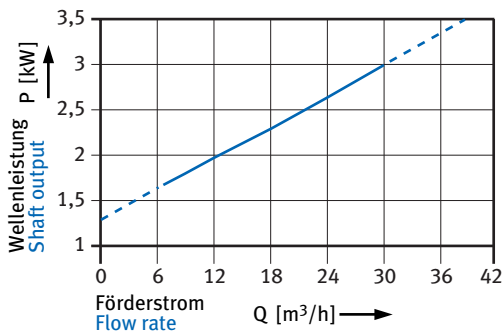
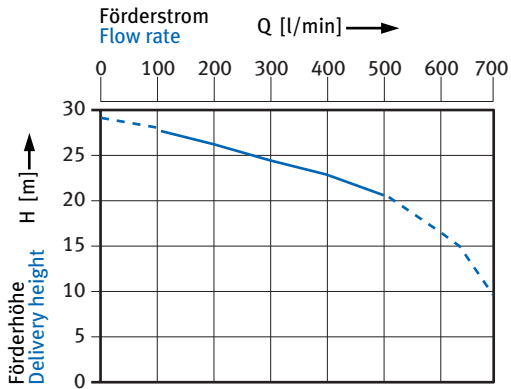

Typ/Type	T ¹⁾	H	G	Gewicht Weight (kg)	Leistung Power (kW)
TS 40-21/22 338	338	320	180	33	2,2
TS 40-21/30 338	338	350	200	37	3
TS 40-21/22 586	586	320	180	40	2,2
TS 40-21/30 586	586	350	200	44	3

Beispiel: Laufrad-Ø = 121 → TS 40-21/30338

Example: Impeller-Ø = 121 → TS 40-21/30338

Max. Korngröße: 15 mm
 Laufrad-Werkstoff: St
 Kennlinien für $\nu = 1 \text{ mm}^2/\text{s}$
 1) Maße in mm

Max. grain size: 15 mm
 Impeller material: St
 Characteristic lines for $\nu = 1 \text{ mm}^2/\text{s}$
 1) Dimensions in mm

Tauchpumpe — TS 40-21/30 338
 Laufradform —
 Baugröße —
 Laufrad-Index —
 Motorleistung x 10 —
 Eintauchtiefe in mm —

Submerged pump — TS 40-21/30 338
 Form of impeller —
 Pump size —
 Impeller-index —
 Motor power x 10 —
 Depth of immersion in mm —

TG 50

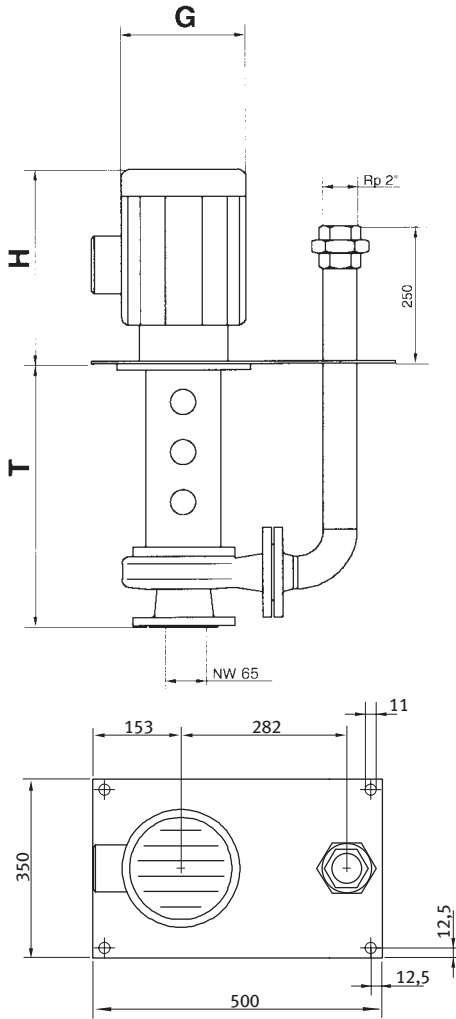

Typ/Type	T ¹⁾	H	G	Gewicht Weight (kg)	Leistung Power (kW)
TG 50-../40 480	480	355	224	68	4,0
TG 50-../55 480	480	355	224	78	5,5
TG 50-../40 840	840	355	224	75	4,0
TG 50-../55 840	840	355	224	85	5,5

Beispiel: Laufrad-Ø = 128 → TG 50-28/55 480

Example: Impeller-Ø = 128 → TG 50-28/55 480

Max. Korngröße: 15 mm
 Laufrad-Werkstoff: GJL-250 (GG 25)
 Kennlinien für $\nu = 1 \text{ mm}^2/\text{s}$

1) Maße in mm

Max. grain size: 15 mm
 Impeller material: GJL-250 (GG 25)
 Characteristic lines for $\nu = 1 \text{ mm}^2/\text{s}$
 1) Dimensions in mm

Tauchpumpe ——— TG 50-28/55 480
 Laufradform ———
 Baugröße ———
 Laufrad-Index ———
 Motorleistung x 10 ———
 Eintauchtiefe in mm ———

Nenn Drehzahl / Nominal rotation speed 2900 min⁻¹@ 50Hz

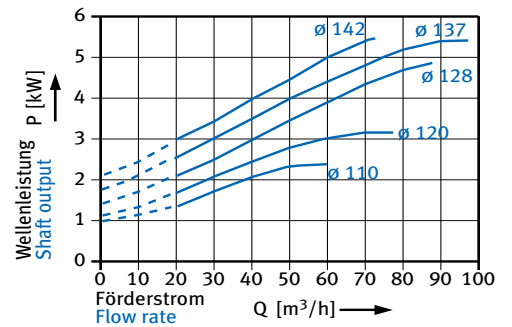
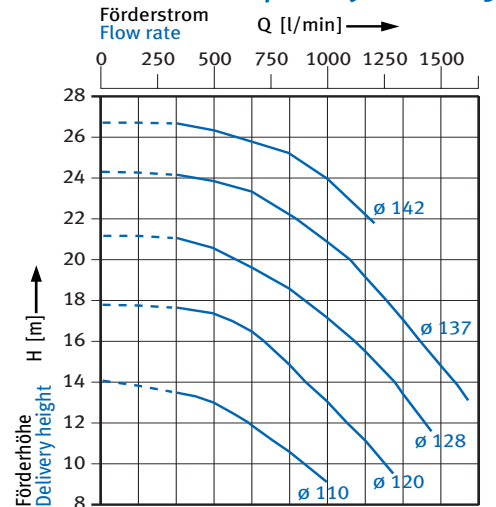

Nenn Drehzahl / Nominal rotation speed 3500 min⁻¹@ 60Hz

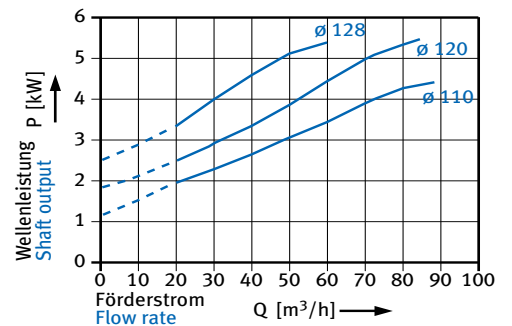
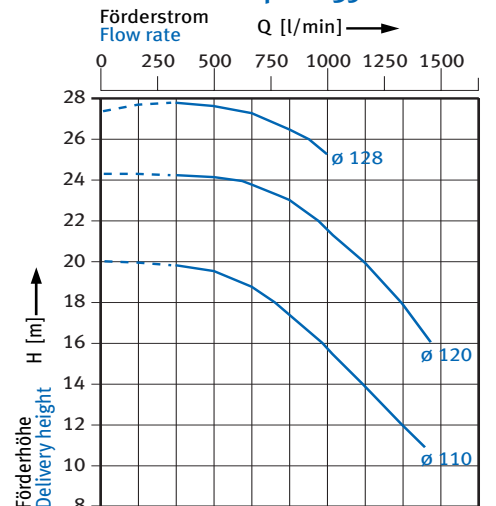

Submerged pump ——— TG 50-28/55 480
 Form of impeller ———
 Pump size ———
 Impeller-index ———
 Motor power x 10 ———
 Depth of immersion in mm ———

TF 50

Nenn Drehzahl / Nominal rotation speed 2900 min⁻¹ @ 50Hz

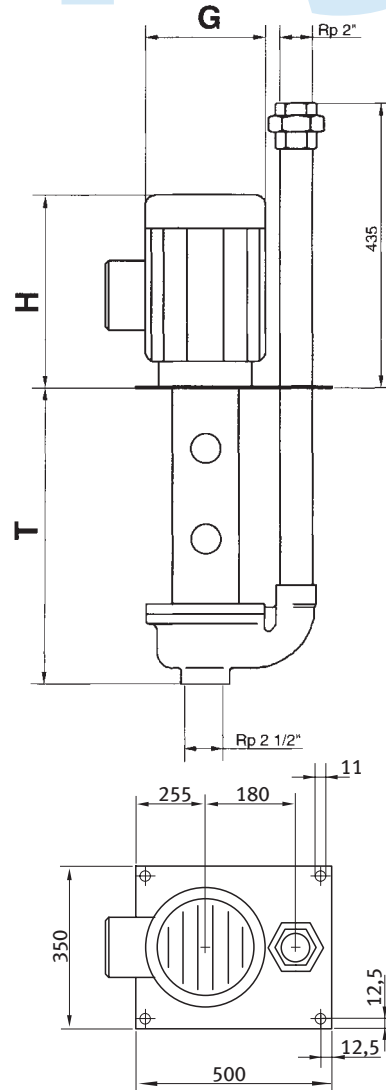
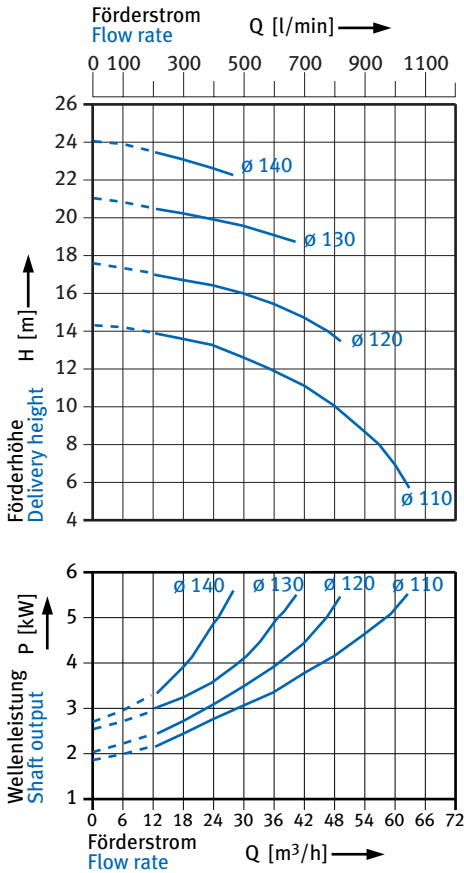

Nenn Drehzahl / Nominal rotation speed 3500 min⁻¹ @ 60Hz

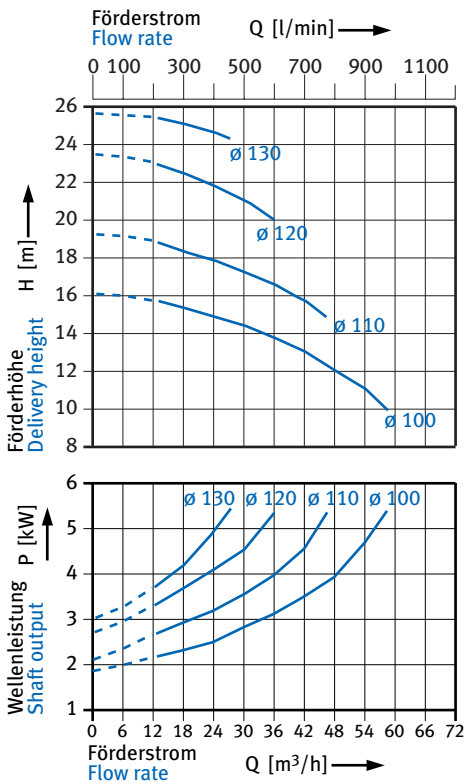

Typ/Type	T ¹⁾	H	G	Gewicht Weight (kg)	Leistung Power (kW)
TF 50-../40 488	488	355	224	68	4,0
TF 50-../55 488	488	355	224	78	5,5
TF 50-../40 848	848	355	224	75	4,0
TF 50-../55 848	848	355	224	85	5,5

Beispiel: Laufrad-Ø = 140 → TF 50-40/55 488

Example: Impeller-Ø = 140 → TF 50-40/55 488

Max. Korngröße: 30 mm
 Laufrad-Werkstoff: GJL-250 (GG 25)
 Kennlinien für $\nu = 1 \text{ mm}^2/\text{s}$
 1) Maße in mm

Max. grain size: 30 mm
 Impeller material: GJL-250 (GG 25)
 Characteristic lines for $\nu = 1 \text{ mm}^2/\text{s}$
 1) Dimensions in mm

Tauchpumpe — TF 50-40/55 488
 Laufradform —
 Baugröße —
 Laufrad-Index —
 Motorleistung x 10 —
 Eintauchtiefe in mm —

Submerged pump — TF 50-40/55 488
 Form of impeller —
 Pump size —
 Impeller-index —
 Motor power x 10 —
 Depth of immersion in mm —

KNOLL

.It works

KNOLL Maschinenbau GmbH

Schwarzachstraße 20
D-88348 Bad Saulgau
Tel. + 49 (0) 75 81/20 08-0
Fax + 49 (0) 75 81/20 08-140
info.itworks@knoll-mb.de
www.knoll-mb.de

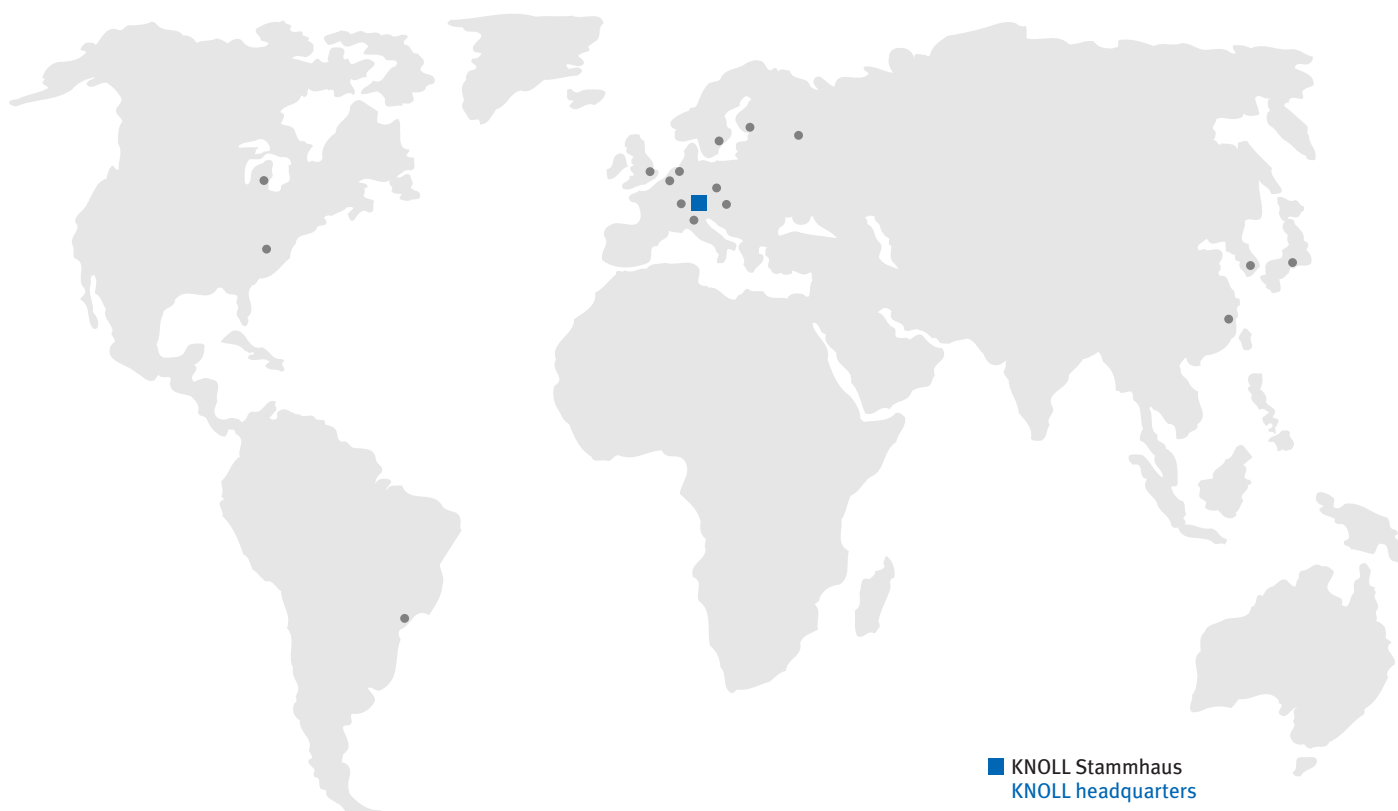

- KNOLL Stammhaus
KNOLL headquarters
- KNOLL Vertretungen
KNOLL representations